

By  
**D. BOLLEN**

**PEAC**

# ANALOGUE COMPUTER

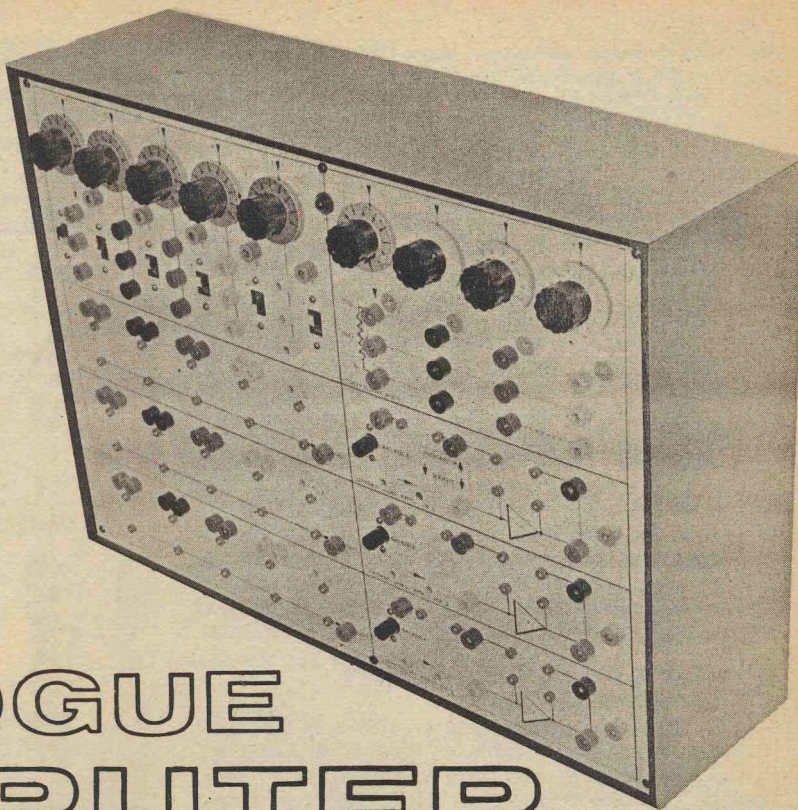

**T**HE constructional details for UNIT "A" were completed last month. UNIT "A" is, itself, a complete, self-contained computing equipment, and the method of operation, with practical examples, is described in this article.

## PATCHING LEADS

The best plugs to use for patching the computer are those of "split-pin" construction, as they can quickly be attached to wires without the aid of a screwdriver. It is a help if plugs are obtained in various colours, and are mated to different coloured wires to allow easy identification.

For the majority of problems capable of solution by UNIT "A", certain patching leads may be left in position on the front panel. For example, coefficient potentiometers are almost always used with the "0" end of their resistance track connected to earth (link SK3 to SK4 for CP1, CP2, CP3, and CP4, Fig. 2.7).

Similarly, until such time as integrator mode switching is brought into use, the integrator sockets depicted in Fig. 2.9 are joined together by means of a special three-way patching lead consisting of two short lengths of wire joined by a plug, with a plug at each end. Looking at Fig. 2.9, OA1/SK4, SK9, and SK10 are linked, and repeat for OA2 and OA3. Three more semi-permanent patching leads are made up to link each operational amplifier to its companion summer network. Connect OA1/SK8 to S1/SK5, and do the same for OA2/SK8-S2/SK5, and OA3/SK8-S3/SK5.

The rearrangeable patching leads should be of assorted lengths and colours, the longest to patch from, say, CP4/SK2 to S3/I1/SK1, diagonally across the UNIT "A" front panel, and the shortest to link nearly adjacent sockets.

## COMPUTING RESISTORS

If a comprehensive range of  $\pm 1$  per cent high stability computing resistors was purchased all at once, to meet every requirement, the cost would probably exceed £20. There are after all 101 preferred values in a  $\pm 1$  per cent range covering resistors from only 10 kilohm to 100 kilohm. Nevertheless, in the period when the computer operator is learning how to handle PEAC, and a high degree of accuracy is not essential, the majority of ordinary problem set-ups can be catered for by a small number of  $\pm 1$  per cent and  $\pm 2$  per cent plug-in resistors. A resistor selection list, with suggested values of  $R_f$  and  $R_{in}$  for standard op-amp closed-loop gains, is given in Table 4.1. Also, a component list included in this article sets out minimum quantities, with tolerances, of computing resistors.

Computing capacitors will be discussed later, in connection with integration.

## SETTING UP THE VOLTAGE SOURCE

To set up all voltage source outputs, first remove the dials from VR6 to VR10 (Fig. 2.2), and turn the potentiometer spindles fully anticlockwise. If the potentiometers have flats on their spindles, make up blanking pieces consisting of small segments of hardwood or plastic, so that control knobs can be conveniently located at a selected position on each spindle. Connect the positive lead of a sensitive d.c. voltmeter (0-1V, 20 kilohm/V) to VS1/SK1, and the negative voltmeter lead to VS1/SK4 (Fig. 2.6), then set slide switch S1 for a positive voltage output. Switch on the computer power supply and S6.

Carefully rotate VR6 spindle clockwise until a very small voltage appears, just sufficient to slightly deflect

the meter pointer away from zero. Now place a dial knob on VR6 spindle, without disturbing the potentiometer setting, and align so that the "0" division on the dial is vertical and opposite the pointer mark on the surface of the front panel. Tighten the dial knob grub screw.

Switch off S6 and replace the 0-1V meter with the 0-10V d.c. meter which has been chosen to serve as a voltage standard for the computer, while retaining the same meter lead polarity. Rotate VR6 dial until the "10" division is opposite its pointer, and switch on S6. Now adjust slider resistor VR1 from the back of the UNIT "A" box, for a precise reading of 10V on the "standard" meter. Repeat the above procedures for outputs VS2, VS3, VS4, and VS5, and remember to adjust only the particular slider (VR1-VR5) which is associated with the output being set up.

When all the voltage source dials are aligned, return to VS1 and make sure that its output is still +10V. Switch off S6, reverse the "standard" voltmeter leads, and set S1 for a negative output. Switch on S6 again and check the voltmeter reading; if it is not exactly 10V, go to the back of the UNIT "A" box and trim the power pack control VR2 (Fig. 3.4), this ensures that voltage source negative and positive outputs are equal.

#### SETTING UP THE COEFFICIENT POTENTIOMETERS

Insert a patching lead to link CP1/SK3 to CP1/SK4 (Fig. 2.7), and do the same for CP2, CP3, and CP4. Take a long patching lead from VS1/SK1 to CP1/SK1. Remove the dial from VR11 (Fig. 2.5) and rotate spindle fully clockwise. With the negative lead connected to any earth socket, insert the "standard" meter positive lead into CP1/SK2 after first setting S1 for a positive output. Adjust VS1 dial for a meter reading of 10V. Rotate CP1 spindle carefully anti-clockwise until the meter pointer just begins to drop below the 10V division. Replace CP1 dial knob on VR11 spindle, align the "10" division with the pointer, and tighten the grub screw. Repeat for CP2, CP3, CP4.

With a 10V input to CP1/SK1, and a 0-10V meter connected to CP1/SK2, it is a simple matter to check the agreement between dial divisions and voltage output from the coefficient potentiometer. If there are serious discrepancies between voltage output and dial reading this will indicate that the effective electrical rotation of the potentiometer differs from the 270 degree dial calibration. Errors can often be minimised by slight readjustment of the dial knob on its spindle, to spread the error over the entire scale. Generally

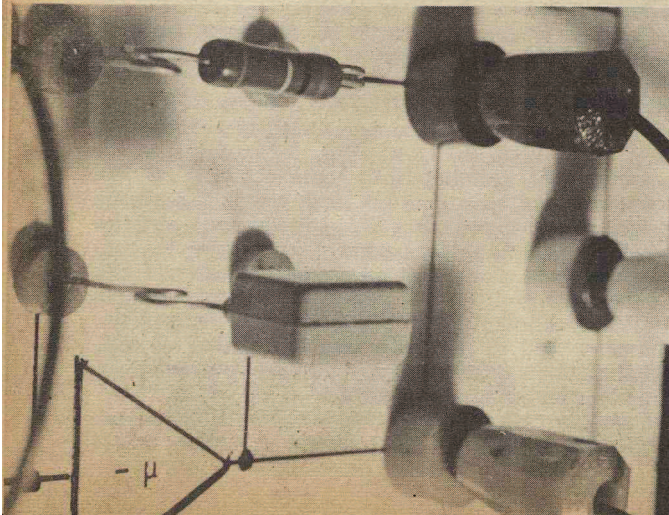

**TABLE 4.1**  
SUGGESTED VALUES OF COMPUTING RESISTOR FOR STANDARD CLOSED-LOOP GAINS

Op-amp gain $\frac{R_f}{R_{in}} = -G$	All resistors $\pm 2\%$ unless otherwise stated	
	$R_{in}$	$R_f$
0.1	100k $\Omega$	10k $\Omega$
0.2	100k $\Omega$	20k $\Omega$
0.3	33k $\Omega$	10k $\Omega$
0.4	40k $\Omega \pm 1\%$	10k $\Omega$
0.5	20k $\Omega$	10k $\Omega$
0.6	33k $\Omega$	20k $\Omega$
0.7	13k $\Omega$	9.1k $\Omega$
0.8	20k $\Omega$	16k $\Omega$
0.9	20k $\Omega$	18k $\Omega$
1.0	10k $\Omega$	10k $\Omega$
2.0	100k $\Omega$	100k $\Omega$
	10k $\Omega$	20k $\Omega$
3.0	3.3k $\Omega$	10k $\Omega$
	33k $\Omega$	100k $\Omega$
4.0	4k $\Omega \pm 1\%$	10k $\Omega$
	40k $\Omega \pm 1\%$	100k $\Omega$
5.0	20k $\Omega$	100k $\Omega$
6.0	3.3k $\Omega$	20k $\Omega$
7.0	13k $\Omega$	91k $\Omega$
8.0	2k $\Omega$	16k $\Omega$
9.0	2k $\Omega$	18k $\Omega$
10.0	10k $\Omega$	100k $\Omega$
20.0	5k $\Omega \pm 1\%$	100k $\Omega$
30.0	3.3k $\Omega$	100k $\Omega$
40.0	4k $\Omega \pm 1\%$	100k $\Omega$
50.0	2k $\Omega$	100k $\Omega$

speaking, the dial setting error should not be worse than 5 per cent at all settings between "1" and "10" dial divisions. The whole question of computing potentiometer accuracy will be raised later, in connection with the Master Potentiometer of UNIT "B".

#### SETTING UP THE OPERATIONAL AMPLIFIERS

It is usual to check operational amplifiers either before the start of a computation, or at the beginning of the day, but the computer builder may wish to assure himself that his amplifiers are all that they should be when first brought into service. The zero-setting procedure given at the end of Part 3 of this series will have eliminated all but obscure faults. The front panel balance controls (VR15, VR16, and VR17, Figs. 2.4 and 2.9) are deliberately designed to have a limited range of adjustment, so that an amplifier fault will be clearly indicated as an inability to zero-set from the front panel.

To quickly check each amplifier, insert 10 kilohm feedback resistors into miniature sockets SK11 and SK12 for OA1, OA2, and OA3 (Fig. 2.9), and ensure that the operational amplifiers are already linked to their summing networks. Insert 10 kilohm input resistors into S1/I1/SK3-SK4, S2/I1/SK3-SK4, and S3/I1/SK3-SK4 (Fig. 2.8). Patch VS1/SK1 to S1/I1/SK1 (Figs. 2.6 and 2.8) and connect the negative lead of a voltmeter to OA1/SK13, with the positive lead going to any convenient earth socket.

Check that OA1 output is exactly zero when S6 is off. If not, zero-set by means of balance control VR15. Obtain a positive voltage from VS1 by switching on S6 and setting S1 and VR6, and monitor VS1 output with a second voltmeter connected to SN1/SK2 red, and an

# COMPONENTS . . .

## UNIT "A" COMPUTING RESISTORS AND PATCHING LEADS

- Resistors**
- 3 off 2kΩ ± 2%
  - 3 off 3.3kΩ ± 2%
  - 3 off 4kΩ ± 1%
  - 3 off 5kΩ ± 1%
  - 3 off 9.1kΩ ± 2%
  - 5 off 10kΩ ± 1%
  - 5 off 10kΩ ± 2%
  - 3 off 13kΩ ± 2%
  - 3 off 15kΩ ± 2%
  - 3 off 16kΩ ± 2%
  - 3 off 18kΩ ± 2%
  - 3 off 20kΩ ± 2%
  - 3 off 33kΩ ± 2%
  - 3 off 40kΩ ± 1%
  - 3 off 91kΩ ± 2%
  - 5 off 100kΩ ± 1%
  - 5 off 100kΩ ± 2%

(All metal oxide or carbon film, 1W)

### Plugs

1 dozen of each colour: red, black, blue, yellow, and white, to fit front panel sockets (see text).  
1 dozen miniature plugs, to fit miniature sockets

### Wire

Stranded core single p.v.c. wires in assorted colours (14/0076in).

Fig. 4.1. (right) These diagrams indicate how the operational amplifier can be used to solve various algebraic equations

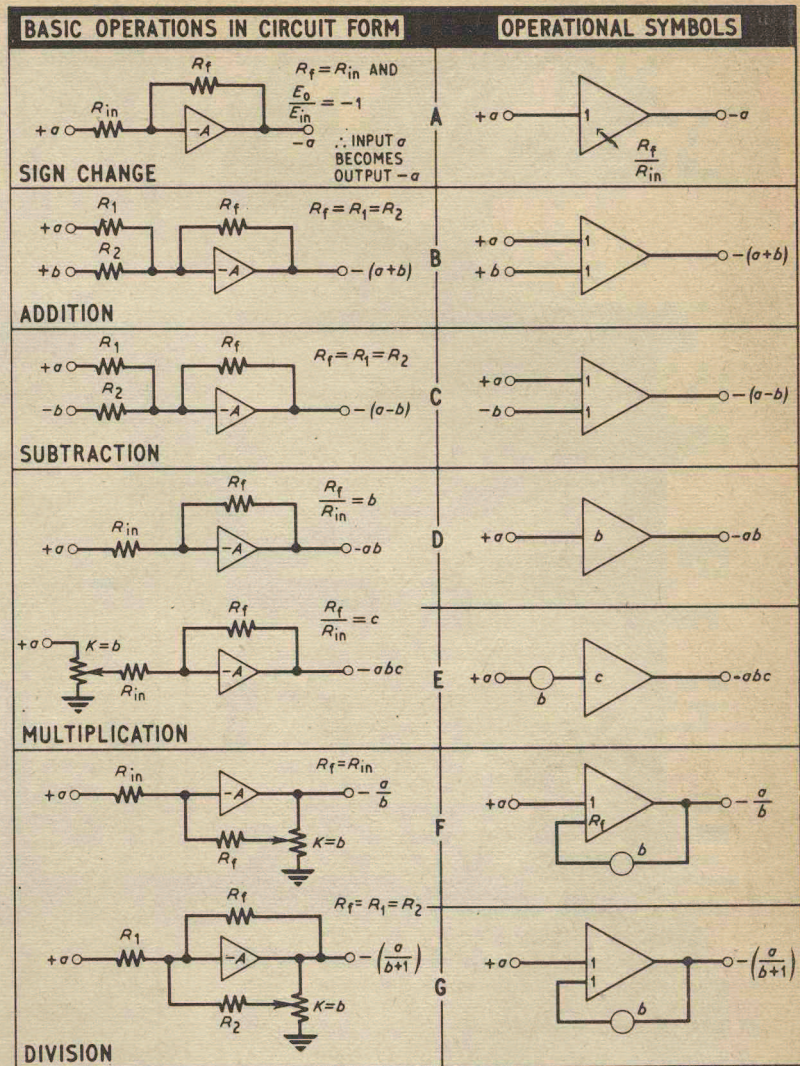

earth socket. Remember that a positive input voltage results in a negative operational amplifier output voltage.

Since input and feedback resistors are both 10 kilohm, the operational amplifier gain will be unity, and both voltmeters should give precisely the same readings. Double check by interchanging voltmeters. Now see that the operational amplifier will faithfully "track" any input voltage of ±10V or less when a temporary output load of 2 kilohm is connected from OA1/SK7 to earth.

The above tests are repeated for OA2 and OA3 by transferring the patching lead from VS1-S1/I1/SK1 to S2/I1/SK1, and then to S3/I1/SK1, and at the same time reconnecting voltmeters to the appropriate summer and operational amplifier sockets.

## SOFTWARE

Under the heading of "software" comes all the paperwork associated with drawing up a programme for the computer. The time spent on preparing a programme for PEAC can vary from a few minutes to several days, depending on the skill of the programmer and the nature and complexity of the problem.

The intention is to give a few typical programme examples as an introduction to using the computer.

They will consist of a short written routine, plus programme layouts. The layouts will be in a duplicated form, of symbolised diagram and patching circuit, so that the reader can compare analogue computer symbols with actual circuits and patching procedures. A newcomer to analogue computers will best learn programming techniques by working with PEAC, and this will also help to increase his knowledge of more advanced mathematics.

## ROLE OF THE OPERATIONAL AMPLIFIER IN EQUATION SOLVING

Now that the time has come to consider UNIT "A" as a computer, instead of as a collection of circuits handling voltages, it is appropriate to adopt a slightly different approach. Voltages will now be replaced by the letters or numbers of an algebraic equation,  $a, b, c, d, x, y, 2, 3, 4, 5$ , and so on. Computing resistors lose their individual identity and are considered only as ratios  $\frac{R_f}{R_1}, \frac{R_f}{R_2}$ , etc., which are also denoted by coefficient letters or numbers. The same applies to coefficient potentiometer settings.

**Sign change.** In the circuit of Fig. 4.1a, an input voltage classified as term  $a$ , reappears at the op-amp

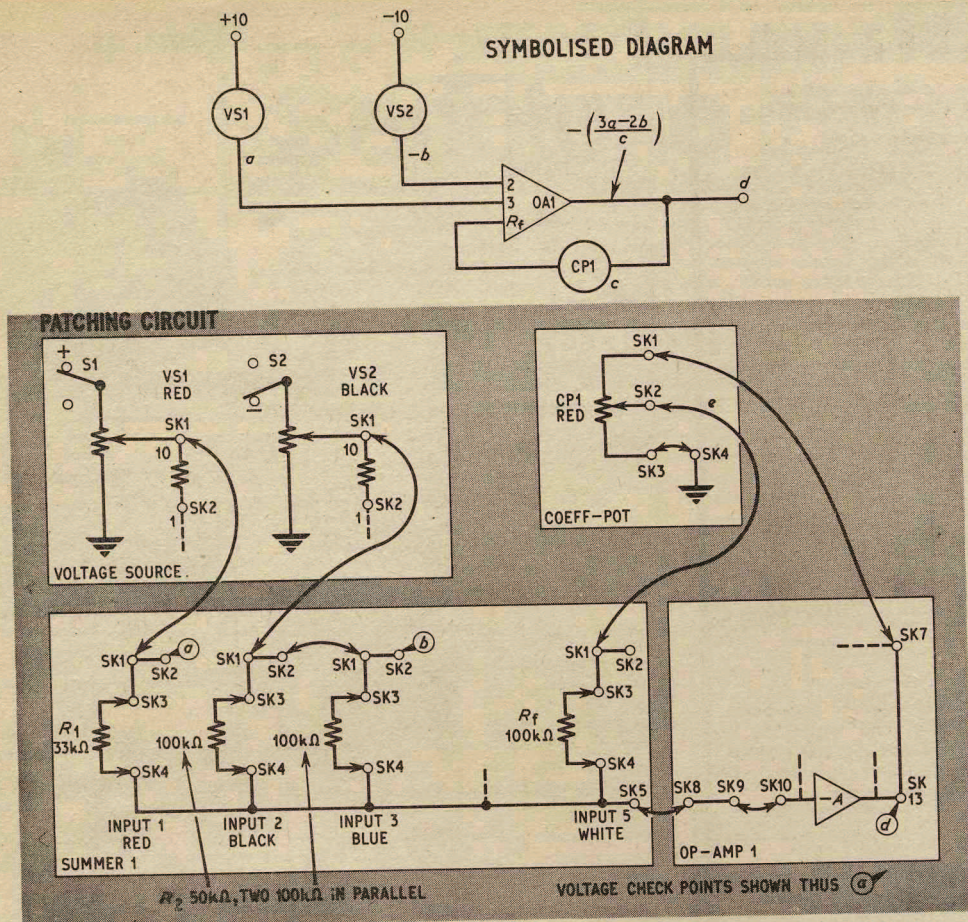

Fig. 4.2 Programme layouts for  $\frac{3a - 2b}{c} = d$

output as term  $-a$ , when the  $\frac{R_f}{R_{in}}$  ratio is unity. One way of looking at this operation, which is common to all single operational amplifier configurations, is to assume that  $a$  has been multiplied by  $-1$ , hence  $\frac{R_f}{R_{in}} = -1$ . In effect, to multiply by  $-1$  is to move a mathematical term from one side of its equation to the other, so sign change can be used to transpose.

The operational symbol of Fig. 4.1a avoids the bother of inserting resistors and their values when drawing up a programme layout on paper. The figure inside the triangle—in this case “1”—merely indicates that the computing resistor ratio, or alternatively the operational amplifier gain, is unity.

**Addition.** In Fig. 4.1b, positive terms  $a$  and  $b$  are added to yield an output  $-(a + b)$ , which can also be written  $-a - b$ . If  $-(a + b)$  is applied as an input to a second unity gain operational amplifier, to give two sign changes, it will be converted to  $a + b$ . Note that the figures in the operational symbol show that  $\frac{R_f}{R_1} = 1$ , and  $\frac{R_f}{R_2} = 1$ .

**Subtraction.** The only difference between Fig. 4.2b and Fig. 4.2c is that term  $b$  has been made a negative quantity. The operational amplifier output is therefore  $-(a - b)$  or  $-a + b$ .

**Multiplication.** In Fig. 4.1d,  $R_f$  and  $R_{in}$  are adjusted so that  $\frac{R_f}{R_{in}} = b$ . Hence,  $a$  is multiplied by factor  $b$  to become an output  $-ab$ . The letter inside the operational symbol triangle shows that the  $\frac{R_f}{R_{in}}$  ratio is  $b$ .

Fig. 4.1e gives an alternative method of achieving multiplication. A computing potentiometer is connected to the op-amp input to multiply  $a$  by a factor  $b$ . Therefore, with an input  $ab$ , and  $\frac{R_f}{R_{in}}$  adjusted to equal  $c$ , the result is an output  $-abc$ .

**Division.** When a computing potentiometer is wired as in Fig. 4.1f, with  $R_f$  connected to its slider, term  $a$  will be divided by constant  $b$  when  $R_f = R_{in}$ . Note that  $R_f$  is written inside the symbol triangle to show that  $b$  is a divisor.

It can sometimes happen that a feedback resistor is inadvertently left plugged into an operational amplifier when it is re-programmed for a division operation, and this will result in the circuit of Fig. 4.1g. Instead of an

output  $-\frac{a}{b}$  the operational amplifier will yield  $-\left(\frac{a}{b+1}\right)$ .

## COMBINED OPERATIONS

The configurations of Fig. 4.1 have many similarities, which lead naturally to the combination of several operations. In fact, it is possible to perform, say, ten additions or subtractions, three multiplications, and one division operation all at once using a single operational amplifier with several inputs and coefficient potentiometers.

### PROBLEM EXAMPLE 1. SOLVING A SIMPLE EQUATION

UNIT "A" can solve a linear algebraic equation consisting of more than ten unlike terms, but a simple example with only four terms will serve as an adequate practical introduction to programming.

$$\text{Take } \frac{3a - 2b}{c} = d \quad (\text{Eq. 4.1})$$

the letters  $a$ ,  $b$ , and  $c$  are regarded as known quantities, and  $d$  is the unknown, but the equation can be transposed to solve for any unknown.

Eq. 4.1 is implemented on the computer as shown in the Fig. 4.2 patching circuit. Two voltages corresponding to  $a$  and  $-b$  are taken from the voltage source to summer S1, where  $a$  is multiplied by  $\frac{R_f}{R_1} = 3$ , and  $-b$

is multiplied by  $\frac{R_f}{R_2} = 2$ .

The machine equation for the problem is,

$$\frac{R_f}{R_1} a - \frac{R_f}{R_2} b = d \quad (\text{Eq. 4.2})$$

and if  $R_f$  is made 100 kilohm the equation will take the form of

$$\frac{100}{33} a - \frac{100}{50} b = d \quad (\text{Eq. 4.3})$$

Computing resistor values could equally well be  $R_f = 10$  kilohm,  $R_1 = 3.3$  kilohm, and  $R_2 = 5$  kilohm, to yield the same multiplication ratios. Since a 50 kilohm resistor is not included in the short list of Table 4.1, two 100 kilohm resistors are patched together in parallel in the patching circuit Fig. 4.2.

**Routine.** To set up Eq. 4.1 on UNIT "A", first of all ensure that the voltage source switch S6 is off. Insert computing resistors into the positions shown in Fig. 4.2 patching circuit, and connect the computing elements together with patching leads. Set VS1 and VS2 dials to zero, and CP1 to "10", corresponding to a divisor of 1. Wire a voltmeter to OA1/SK13 and zero-set the operational amplifier by means of VR15. Next connect a voltmeter to S1/I1/SK2, and switch on S6. Set VS1 dial for a trial value of  $a = 2\text{V}$ . Transfer the voltmeter from S1/I1/SK2 to S1/I3/SK2, and set VS2 dial for a trial value of  $b = -2\text{V}$ .

UNIT "A" will now be computing

$$\frac{(3 \times 2) - (2 \times 2)}{1} = 2 \quad (\text{Eq. 4.4})$$

with  $a = 2$ ,  $b = -2$ ,  $c = 1$ , and therefore  $d = 2$ . When a voltmeter is linked to OA1/SK13 it will be discovered that the output voltage  $d$  is actually  $-2\text{V}$ , due to the operational amplifier sign change. Remedy by reversing the readout meter leads. If the output voltage is not exactly  $-2\text{V}$ , recheck voltages for  $a$  and  $-b$ . To check the exact setting of CP1 dial for any value of  $c$ , temporarily remove the patching lead from CP1/SK1. Patch CP1/SK1 to a precise  $+10\text{V}$  from a

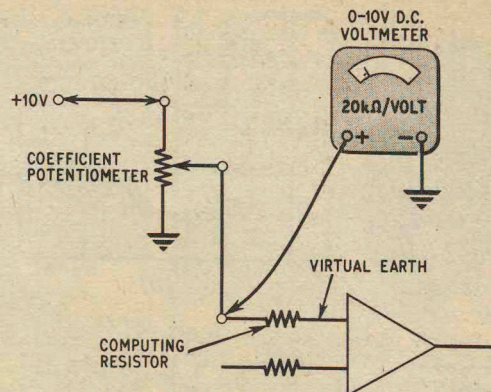

Fig. 4.3. Voltmeter method of determining coefficient potentiometer settings

spare voltage source output, and connect a voltmeter to S1/I5/SK2. The voltmeter will then indicate the potentiometer coefficient while taking into account the loading effect of  $R_f$  (see Fig. 4.3). A voltmeter reading of  $4.75\text{V}$  is equivalent to a coefficient of  $0.475$ . CP1 can now be patched back into the problem set-up. With a 100 kilohm resistor for  $R_f$ , CP1 will be dividing by numbers equal to or less than unity. If  $R_f$  is changed to 10 kilohm, the range covered by CP1 will become 0-10. Therefore, increasing  $c$  by a factor of 10 can be seen quite clearly to be the same as decreasing computing resistor ratios by a factor of 10.

With UNIT "A" now programmed for Eq. 4.1, it is possible to investigate fully the problem for all reasonable values of  $a$ ,  $b$ ,  $c$ , and  $d$ , and for any unknown without the need for transposing terms or altering the problem set-up. For example, to find  $a$  when  $b$ ,  $c$ , and  $d$  are known, set  $b$  and  $c$  and adjust  $a$  for an operational amplifier output equal to  $d$ . Always monitor an input voltage with a voltmeter when it is being adjusted.

To see how serious computing errors can occur at extreme limits, set VS1 and VS2 so that terms  $3a$  and  $-2b$  are virtually equal, and  $d \approx 0$ . Also, set CP1 to near zero and observe that  $d$  will pass beyond the 10V operational amplifier maximum output swing.

### PROBLEM EXAMPLE 2. ANALYSIS OF VOLTAGE DIVIDER CIRCUIT

The voltage divider of Fig. 4.4a is often encountered in electronic circuits. At first sight, a network consisting of only two resistors might be considered far too simple to merit investigation by means of a computer,

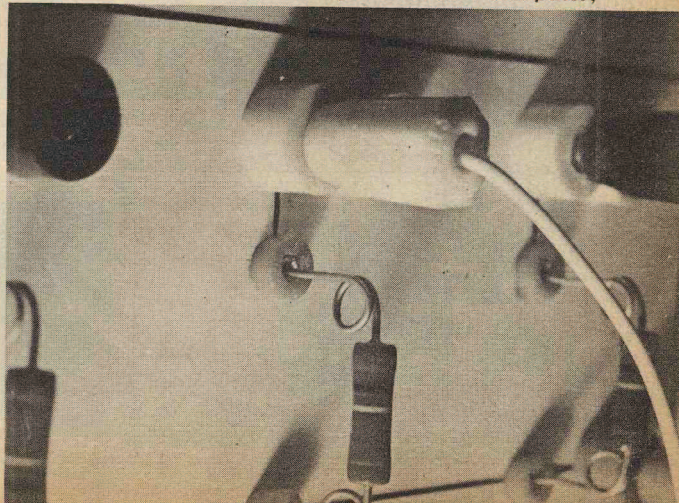

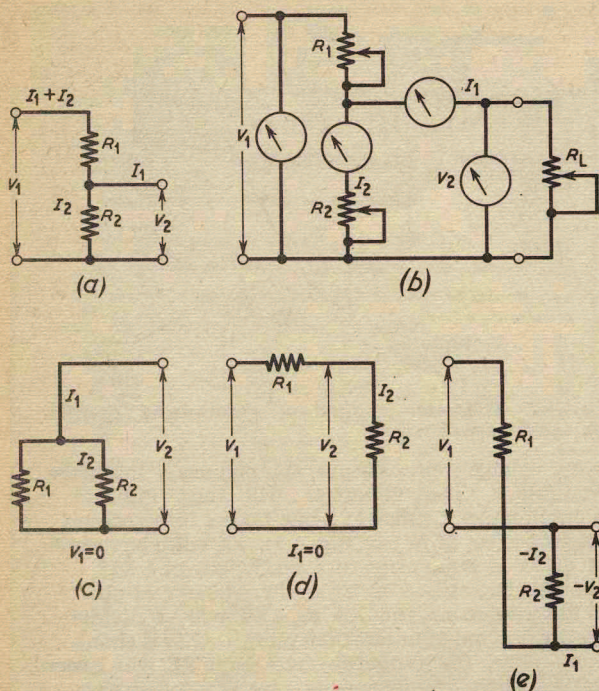

Fig. 4.4. (a) voltage divider circuit; (b) direct simulation of (a); (c), (d) and (e), three variations on (a)

but it does involve at least six variable quantities  $V_1$ ,  $V_2$ ,  $I_1$ ,  $I_2$ ,  $R_1$ , and  $R_2$ , and to solve a problem for any unknown, one of six equations would be required, based on

$$R_1 = \frac{V_1 - V_2}{I_1 + I_2} \quad (\text{Eq. 4.5})$$

and

$$R_2 = \frac{V_2}{I_2} \quad (\text{Eq. 4.6})$$

Thus, although it would be ridiculous to use the computer to find one specific answer to one particular voltage divider problem, the paperwork involved in solving six equations for several sets of variables could become surprisingly laborious. What the computer does in fact allow is the solution to literally any voltage divider problem under any conditions, without the need for re-programming.

To solve Eq. 4.5 and Eq. 4.6 simultaneously on UNIT "A", the equations are first transposed for terms  $V_2$  and  $I_2$ , which are common to both.

$$V_2 = V_1 - R_1(I_1 + I_2) \quad (\text{Eq. 4.7})$$

and

$$I_2 = \frac{V_2}{R_2} \quad (\text{Eq. 4.8})$$

Next, both equations are linked to give a self-enforcing systems, shown diagrammatically as,

$$V_1 - R_1(I_1 + I_2) = V_2 \longrightarrow \frac{V_2}{R_2} = I_2$$

where the answer to Eq. 4.5 is one of the terms of Eq. 4.6 ( $V_2$ ), and the answer to Eq. 4.6 is one of the

Fig. 4.5. Programme layouts for voltage divider analysis (a) (right) symbolised diagram, (b) (below) patching circuit

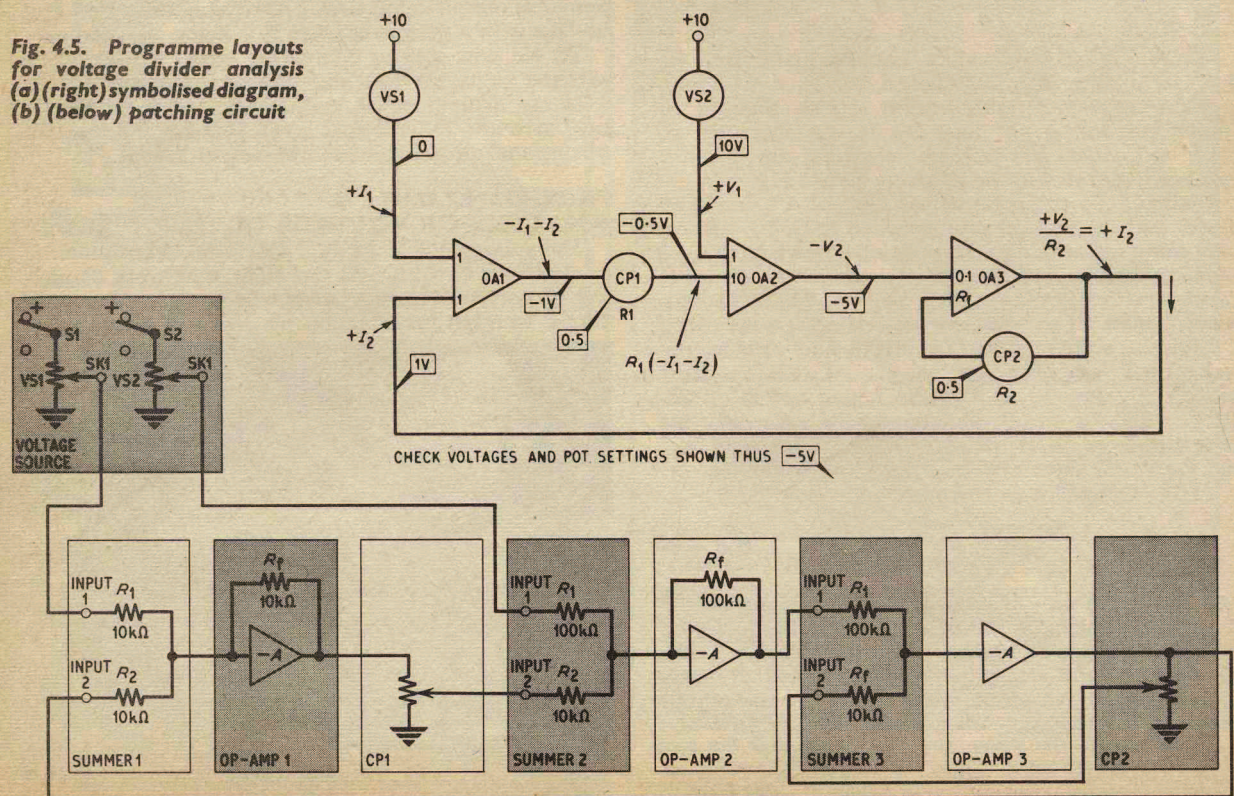

terms of Eq. 4.5 ( $I_2$ ). To see how the problem is set-up on the computer, refer to Fig. 4.5, and note the changes of sign involved.

**Routine.** Switch off S6 and insert all computing resistors and patching leads, except the link between OA3 output and OA1 input, which carries the voltage analogue of  $I_2$ . Zero-set OA1, OA2, and OA3 in that order, using a voltmeter applied to each operational amplifier output socket in turn. Now patch the link between OA3 output and OA1 input into circuit. Set VS1 to "0", and VS2 to "+10". The voltmeter method of Fig. 4.3 is employed to set CP1 and CP2 both for a coefficient of 0.5. Temporarily remove the patching leads from CP1/SK1 and CP2/SK1, and connect the "top end" of the potentiometer tracks to a 10V reference voltage. Adjust CP1 and CP2 for outputs of 5V. Exactly the same procedure is adopted when it is necessary to "read off" values for R1 and R2, although approximate readings can be taken from CP1, CP2 dials.

The check voltages in the diagram of Fig. 4.5 correspond to the above voltage source and coefficient potentiometer settings, and provided that there is general agreement with Ohm's law, any desired values can be given to the voltages, currents, and resistances in Fig. 4.4a. The check voltages could apply to actual voltage divider quantities of, say,  $V_1 = 10V$ ,  $V_2 = 5V$ ,  $I_1 = 0mA$ ,  $I_2 = 1mA$  (1 machine volt = 1mA),  $R_1 = 5$  kilohm, and  $R_2 = 5$  kilohm, where VS1 covers the range 0-10mA, VS2 0-10V, CP1 0-10 kilohm, and CP2 0-10 kilohm. Suppose instead that  $V_1$  had been assigned the value of 1,000V, when  $R_1$  and  $R_2$  were both only 5 ohms. One machine volt would now be equivalent to 100A, and  $V_2$  would equal 500V. The ranges covered by computing potentiometers in the latter case would then be VS1 0-100A, VS2 0-1,000V, CP1 0-100, and CP2 0-10 ohms.

Unless informed otherwise, the computer assumes that  $V_1$  is an ideal voltage which originates from a source of infinitely small resistance. Hence, if  $V_1 = 0$ , this corresponds to a short-circuit, and gives the variation of Fig. 4.4c. Alternatively, if  $I_2$  is made equal to nought, the voltage divider circuit is transformed into a load resistor  $R_2$  in series with a source resistor  $R_1$ , given by Fig. 4.4d.

One further variation will serve to show the flexibility of the programme. In Fig. 4.4e the resistance network  $R_1$  and  $R_2$  is made to couple two sources of voltage  $V_1$  and  $-V_2$ , and this occurs when  $I_1$  is made larger than  $I_1 + I_2$ , or in other words, when  $I_2$  swings negative.

The layout of Problem Example 2 is an instance of indirect simulation, where the computer solves equations and imitates the behaviour of the simulated circuit. In this indirect "model" of a voltage divider, relationships between governing equations and actual circuit parameters are made obvious, and the abstractions of mathematics are brought to life as tangible voltmeter and dial readings.

Another way of simulating the Fig. 4.4a circuit is by a direct "model", shown in Fig. 4.4b, which employs coefficient potentiometers for  $R_1$ ,  $R_L$ , and  $R_2$ , voltmeters for  $V_1$  and  $V_2$ , and current meters for  $I_1$  and  $I_2$ . Although feasible, the direct model is less elegant, is not so adaptable to extreme cases, and is subject to errors which do not occur when the voltage divider is simulated indirectly.

**Next month: Using UNIT "A" to solve a second order differential equation. Indirect simulation of LC circuits, spring pendulums, and servo-mechanisms by means of integrators.**

## REGULATED POWER SUPPLY

continued from page 284

	VOLTS						mA	
	A	B	C	D	E	F	$I_2$	$I_1$
No load current	1.0	0.17	14.2	0.68	0.47	2	65	2.7
	2.88	0.145	11.4	0.5	0.38	6	40	2.1
	5.8	0.12	7.0	0.36	0.28	12	18	1.4
1A Load	0.99	0.165	14.1	0.61	0.40	2	36	1.9
	2.86	0.143	11.3	0.41	0.30	6	18	1.3
	5.78	0.119	6.9	0.23	0.17	12	3.5	0.32

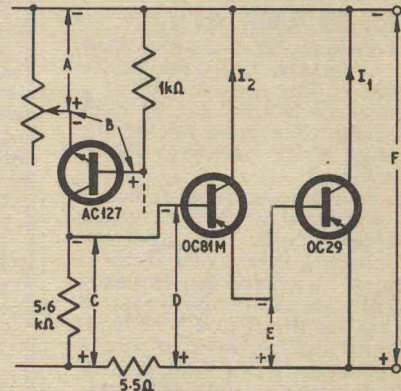

Fig. 10. Test measurements for fault-finding

### CALIBRATION OF OUTPUT VOLTAGE

After checking the voltmeter accuracy against an AVO or similar instrument known to have good accuracy itself, the Regulated Volts dial should be adjusted as follows.

Switch S2 to "Regulated" and S3 to "Volts" and turn VR1 until 1V is obtained at the output (best seen on the AVO). Loosen the knob and rotate to indicate 1V on the calibrated dial. Lock the pointer knob grub screw while indicating the correct 1V. Rotate VR1 until the dial indicates 12V output. Now adjust VR2 until 12V output (measured) is obtained.

### VOLTAGE CHART

Fig. 10 gives typical voltages at six points in the d.c. amplifier circuit for three different output voltages. Reference to these voltages and to the currents of the super-alpha pair TR2, TR3 should assist in any fault-finding. ★

#### INDEX

An index for volume three (January 1967 to December 1967) is now available price 1s 6d inclusive of postage.

#### BINDERS

Easi-binders are available price 14s 6d inclusive of postage. State whether "Vol. 1", "Vol. 2", "Vol. 3" or "Vol. 4" is required.

Orders for Binders and Indexes should be addressed to the Binding Department.

Orders for copies of the Index only should be addressed to the Post Sales Department, George Newnes Ltd., Tower House, Southampton Street, London, W.C.2.